

# SIGN-IN SHEET

**PRE-BID MEETING**

June 14, 2023 at 2:30 PM

<u>NAME</u>	<u>COMPANY</u>	<u>PHONE</u>	<u>EMAIL</u>
Joseph Crane	Feyen Zylstra	231-571-0490	Jcrane@FZLore.com
Scott Henderson	FHC	616-299-2611	scotth@franklinhelwood.com
Joe Stone	Cofesso	231-286-8870	JSTONE@cofesso.com
Dan Vincent	Winberg		
Pat Gordon	Gordon Painting	231-750-2930	gordonpainting11@icloud.com
James VanKee	Free Spirit Cons	231-245-5066	JamesV.VF@geni.com
ADAM WICHTHUIS	MALL CITY MECHANICAL	269-599-2546	AWICHTHUIS@MCM-TEAM.COM
Nick Brown	Freemery Freemery	231-799-8412	nich@infuture.com
Mike Johnson	Real Steel Manufacturing	231-457-4673	mike@realsteelmanufacturing.com
Joe McInnis	C. J. Belg MA	616-745-7721	Joem@ciwin.com
Adam Schultz	Hurst	231-286-3110	aschultz@hurstind.com
Curtis Paulowski	Rhodes		
Lori Pawlitas	Tower Pinkster		
Matt Salvat	Grand Valley Automation	616-292-5491	msalvat@graine.com
Ryan Weber	Schepers Concrete	616-552-2844	Estimator@schepersconcrete.com



# SIGN-IN SHEET

**PRE-BID MEETING** June 14, 2023 at 2:30 PM

<u>NAME</u>	<u>COMPANY</u>	<u>PHONE</u>	<u>EMAIL</u>
Dean Chance	Brigade Fire	616-784-1644	dchance@brigadefire.com
Drew Hansma	Allied Electric	616-340-9094	drew.hansma@alliedelectricinc.com
PATRICK WILHELM	Peckford Const.	616 293-1545	PWILHELM@PeckfordConstruction.com
JEFF GUST	GUST CONST	616 690-5333	JEFF.GUST@ATT.NET
Jim Chrysler	J. Stevens Construction	231-788-4661	j.chrysler@jstevensconstruction.com
Brent Hylland	Wood Trucking	616-638-8836	brylland@gmail.com
CHAD TRAKA	Rhoads Engineering	231-571-5793	ctraka@rhoadsengineering.com
Scott Plummer	Pressures & Pipes	231-578-7370	scott.p@pressuresandpipes.com
John Tangney	North End Painting	231-750-7804	NORTHENDPAINTING@AOL.COM
Seth McElroy	Bullys Masonry	616-204-3060	SETH@BULLYMASONRY.COM
Norm Alverson	Double L Enterprises	231-730-3600	norm@doublelenterprises.com
DEAN ANDERSON	VANS Mech,	616-696-1420	dean@VANSplumbing.com



**SUBSTITUTION REQUEST**  
(During the Bidding/Negotiating Stage)

Project: <u>MHS Performance Gymnasium Addition (23-229969)</u>	Substitution Request Number: <u>SubReq-27636</u>
<u>MONTAGUE, MI</u>	From: <u>Erik Muir, Scranton Products</u>
To: <u>Stacey Brown, Montague Area Public Schools</u>	Date: <u>06/19/2023</u>
<u>browns@mapsk12.org, 231-893-1515</u>	A/E Project Number: _____
Re: <u>Metal Lockers</u>	Contract For: <u>Montague Area Public Schools</u>

Specification Title: <u>Metal Lockers</u>	Description: <u>Athletic Lockers</u>
Section: <u>10 5113</u> Page: <u>2</u>	Article/Paragraph: <u>2.2</u>

Proposed Substitution: <u>Duralife Lockers</u>
Manufacturer: <u>Scranton Products</u> Address: <u>scrantonproducts.com</u> Phone: <u>570-348-0997</u>
Trade Name: <u>Scranton Duralife Lockers</u> Model No.: <u>N/A</u>

Attached data includes product description, specifications, drawings, photographs, and performance and test data adequate for evaluation of the request; applicable portions of the data are clearly identified.

Attached data also includes a description of changes to the Contract Documents that the proposed substitution will require for its proper installation.

**The Undersigned certifies:**

- Proposed substitution has been fully investigated and determined to be equal or superior in all respects to specified product.
- Same warranty will be furnished for proposed substitution as for specified product.
- Same maintenance service and source of replacement parts, as applicable, is available.
- Proposed substitution will have no adverse effect on other trades and will not affect or delay progress schedule.
- Proposed substitution does not affect dimensions and functional clearances.

Submitted by: <u>Erik Muir</u>
Signed by: <u>Erik Muir</u>
Firm: <u>Scranton Products</u>
Address: <u>801 E. Corey Street</u> <u>Scranton, Pennsylvania 18504</u>
Telephone: <u>(570) 348-0997, erik.muir@azekco.com</u>

**A/E' s REVIEW AND ACTION**

- Substitution approved - Make submittals in accordance with Specification Substitution Procedures.
- Substitution approved as noted - Make submittals in accordance with Specification Substitution Procedures.
- Substitution rejected - Use specified materials.
- Substitution Request received too late - Use specified materials.

Signed by: <u>Lori S. Pawlitas</u> <b>APC</b>	Date: <b>6.20.23</b>
---	----------------------

Supporting Data Attached: <input type="checkbox"/> Drawings <input type="checkbox"/> Product Data <input type="checkbox"/> Samples <input type="checkbox"/> Tests <input type="checkbox"/> Reports <input type="checkbox"/> _____
---

**SUBSTITUTION REQUEST**  
(During the Bidding/Negotiating Stage)

Project: <u>MHS Performance Gymnasium Addition (23-229969)</u>	Substitution Request Number: <u>SubReq-27637</u>
<u>MONTAGUE, MI</u>	From: <u>Erik Muir, Scranton Products</u>
To: <u>Stacey Brown, Montague Area Public Schools</u>	Date: <u>06/19/2023</u>
<u>browns@mapsk12.org, 231-893-1515</u>	A/E Project Number: _____
Re: <u>Metal Lockers</u>	Contract For: <u>Montague Area Public Schools</u>

Specification Title: <u>Metal Lockers</u>	Description: <u>Locker Benches</u>
Section: <u>10 5113</u> Page: <u>3</u>	Article/Paragraph: <u>2.4</u>

Proposed Substitution: <u>Tufftec Bench</u>
Manufacturer: <u>Scranton Products</u> Address: <u>scrantonproducts.com</u> Phone: <u>570-348-0997</u>
Trade Name: <u>Scranton Tufftec Bench</u> Model No.: <u>N/A</u>

Attached data includes product description, specifications, drawings, photographs, and performance and test data adequate for evaluation of the request; applicable portions of the data are clearly identified.

Attached data also includes a description of changes to the Contract Documents that the proposed substitution will require for its proper installation.

**The Undersigned certifies:**

- Proposed substitution has been fully investigated and determined to be equal or superior in all respects to specified product.
- Same warranty will be furnished for proposed substitution as for specified product.
- Same maintenance service and source of replacement parts, as applicable, is available.
- Proposed substitution will have no adverse effect on other trades and will not affect or delay progress schedule.
- Proposed substitution does not affect dimensions and functional clearances.

Submitted by: <u>Erik Muir</u>
Signed by: <u>Erik Muir</u>
Firm: <u>Scranton Products</u>
Address: <u>801 E. Corey Street</u>
<u>Scranton, Pennsylvania 18504</u>
Telephone: <u>(570) 348-0997, erik.muir@azekco.com</u>

**A/E' s REVIEW AND ACTION**

- Substitution approved - Make submittals in accordance with Specification Substitution Procedures.
- Substitution approved as noted - Make submittals in accordance with Specification Substitution Procedures.
- Substitution rejected - Use specified materials.
- Substitution Request received too late - Use specified materials.

Signed by: <u>Lori S. Pawlitas</u> <b>APC</b>	Date: <b>6.19.23</b>
---	----------------------

Supporting Data Attached: <input type="checkbox"/> Drawings <input type="checkbox"/> Product Data <input type="checkbox"/> Samples <input type="checkbox"/> Tests <input type="checkbox"/> Reports <input type="checkbox"/> _____
---

SECTION 00 4325 - SUBSTITUTION DURING PROCUREMENT REQUEST FORM

1.1 INTRODUCTORY INFORMATION

- A. Date: 6/15/23
- B. Requesting substitution of ALUMINUM STOREFRONT FRAMING
- C. As specified in Section 084113
- D. Requested Substitute Product: CMI CTS 6" FRAMING

1.2 SUBMITTING PARTY'S STATEMENT

- A. Circle "Y" for yes and "N" for no for each of the following statements and submit supporting data. Indicate impact for all statements below answered as no, with supporting data:

1.  [Y]  [N] Requested substitution offers Owner a substantial advantage in cost, time, energy conservation, or other considerations, after deducting additional responsibilities Owner must assume. Owner's additional responsibilities may include compensation to Architect for redesign and evaluation services, increased cost of other construction by Owner, and similar considerations.
2.  [Y]  [N] Requested substitution does not require extensive revisions to the Contract Documents.
3.  [Y]  [N] Requested substitution is consistent with the Contract Documents and will produce indicated results.
4.  [Y]  [N] Substitution request is fully documented and properly submitted in accordance with "Product Substitution" and "Submittals" Articles in Division 01 Section "Product Requirements."
5.  [Y]  [N] Requested substitution will not adversely affect Contractor's Construction Schedule.
6.  [Y]  [N] Requested substitution has received necessary approvals of authorities having jurisdiction.
7.  [Y]  [N] Requested substitution is compatible with other portions of the Work.
8.  [Y]  [N] Requested substitution has been coordinated with other portions of the Work.
9.  [Y]  [N] Requested substitution provides specified warranty.

- B. I hereby certify that the above statements are true.

C.   
D. Submitter's signature

END OF DOCUMENT 00 4325

Substitution approved on 6.20.23 by *Lori S. Pawlitas* APC

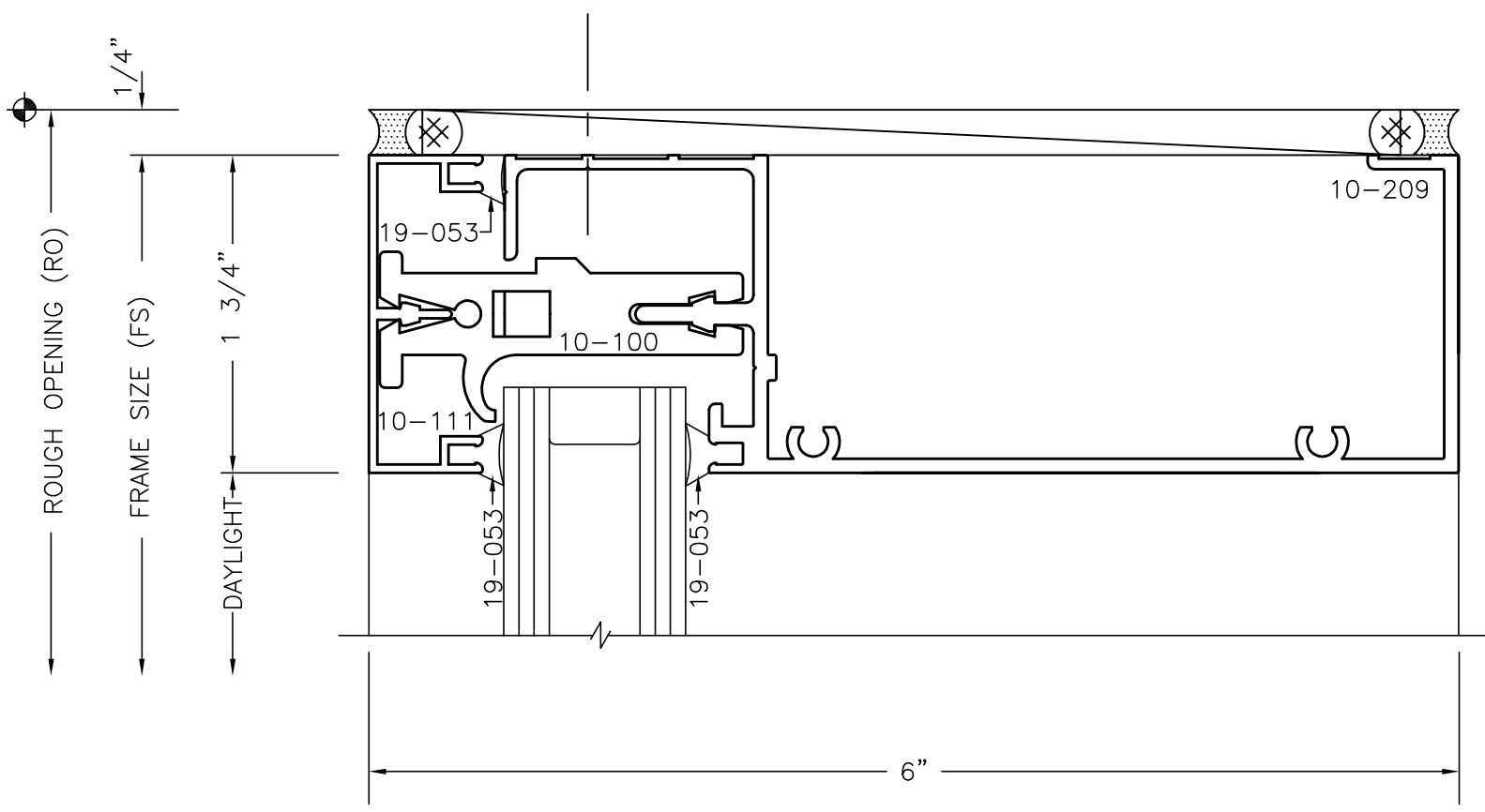

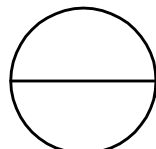
 HEAD  
 SCALE: (1=1) "

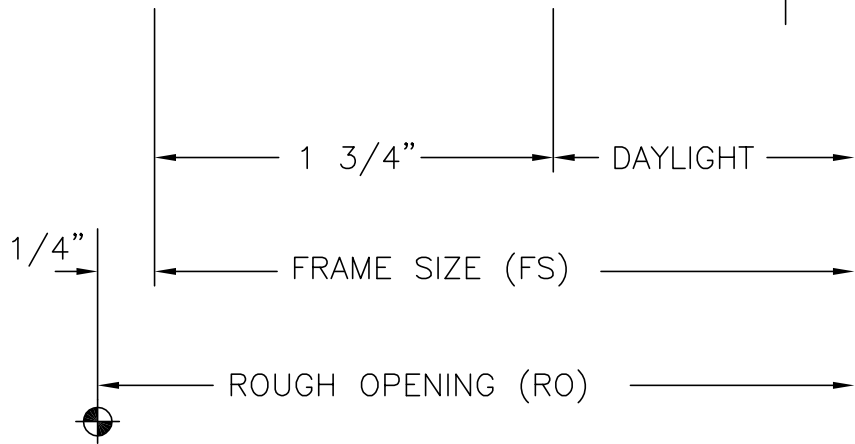
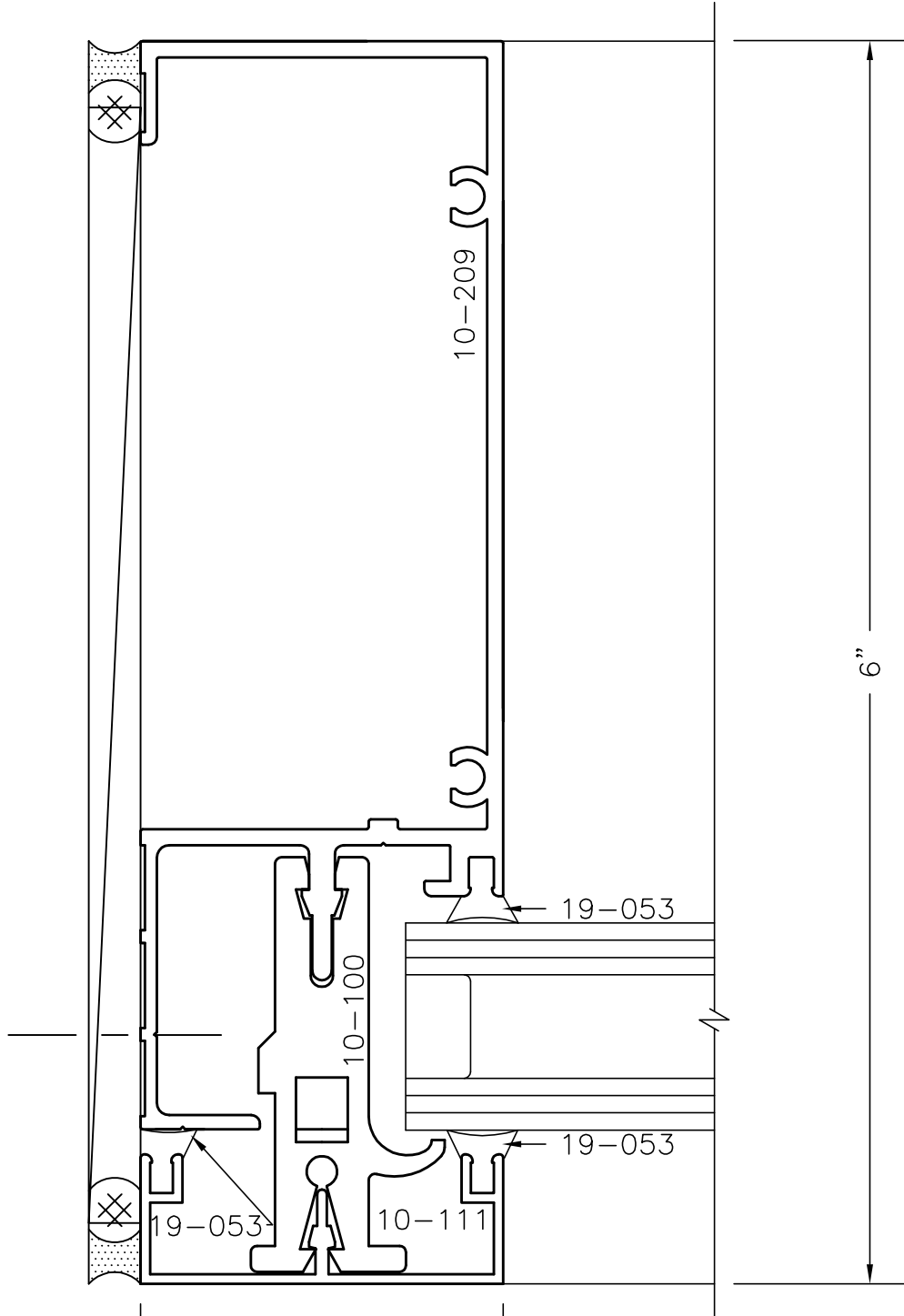

JAMB  
 SCALE: (1=1) "



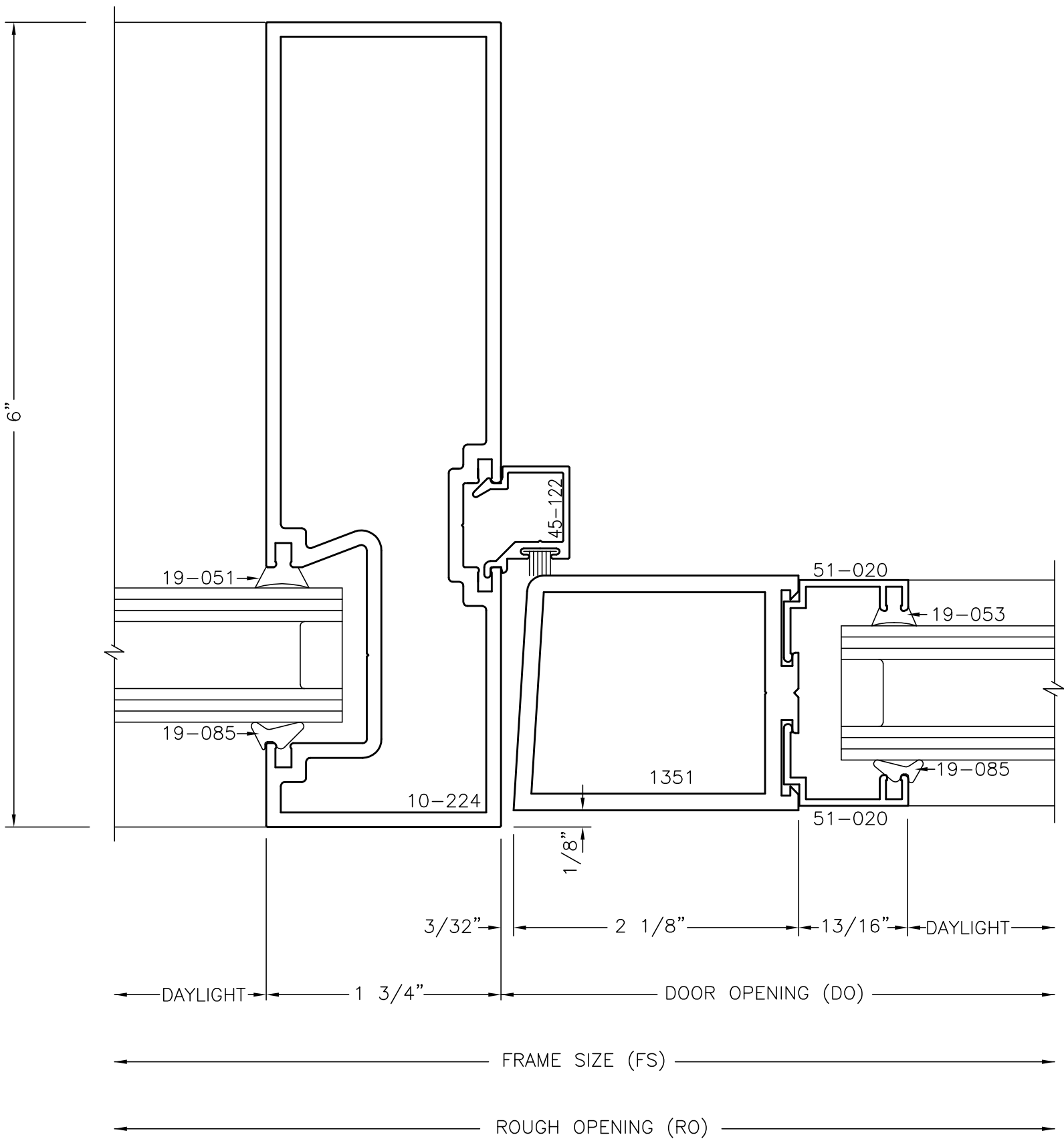

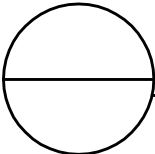

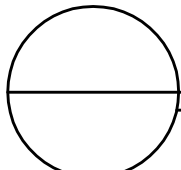
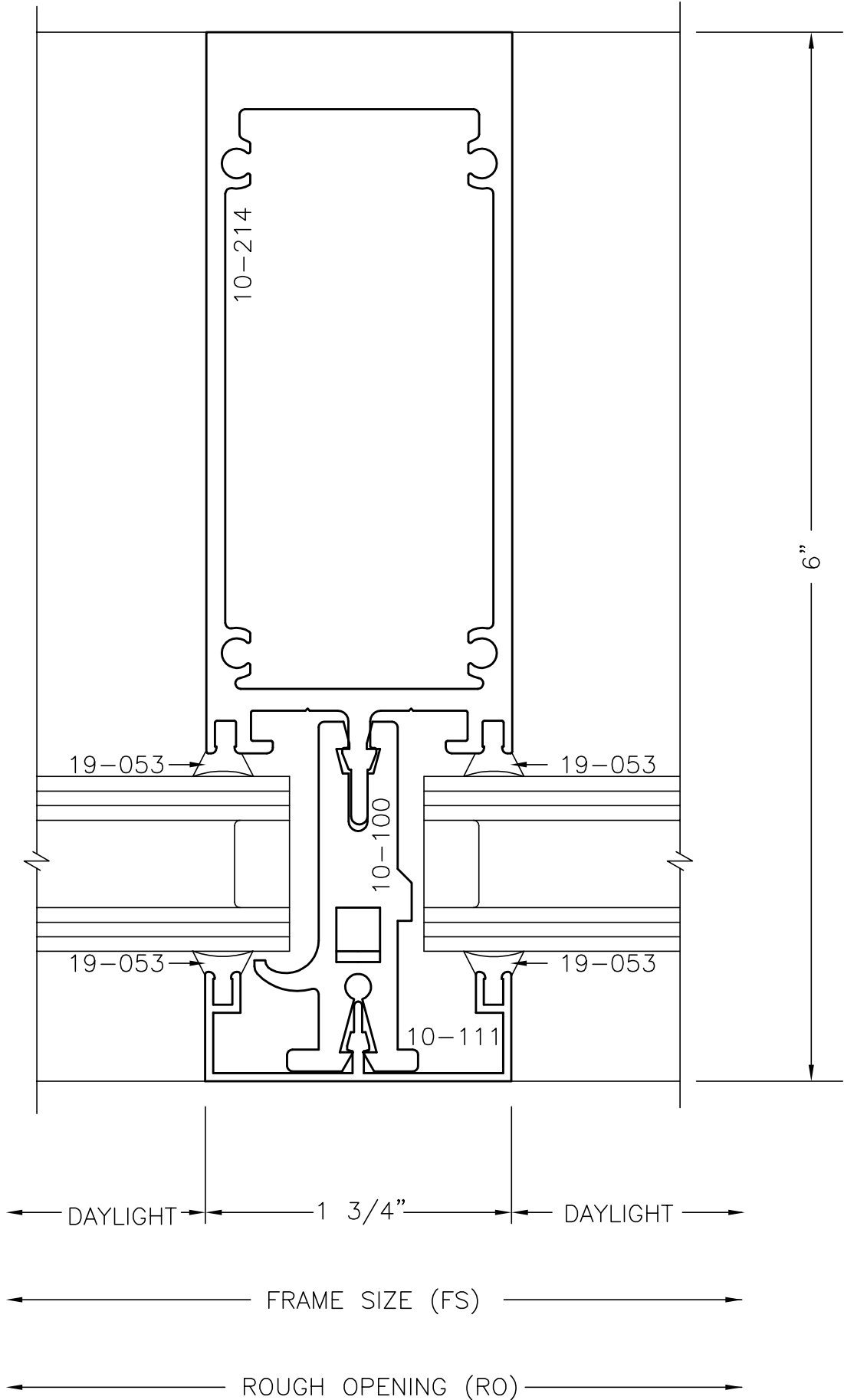
**JAMB - SIDELITE**  
 SCALE: (1=1) "

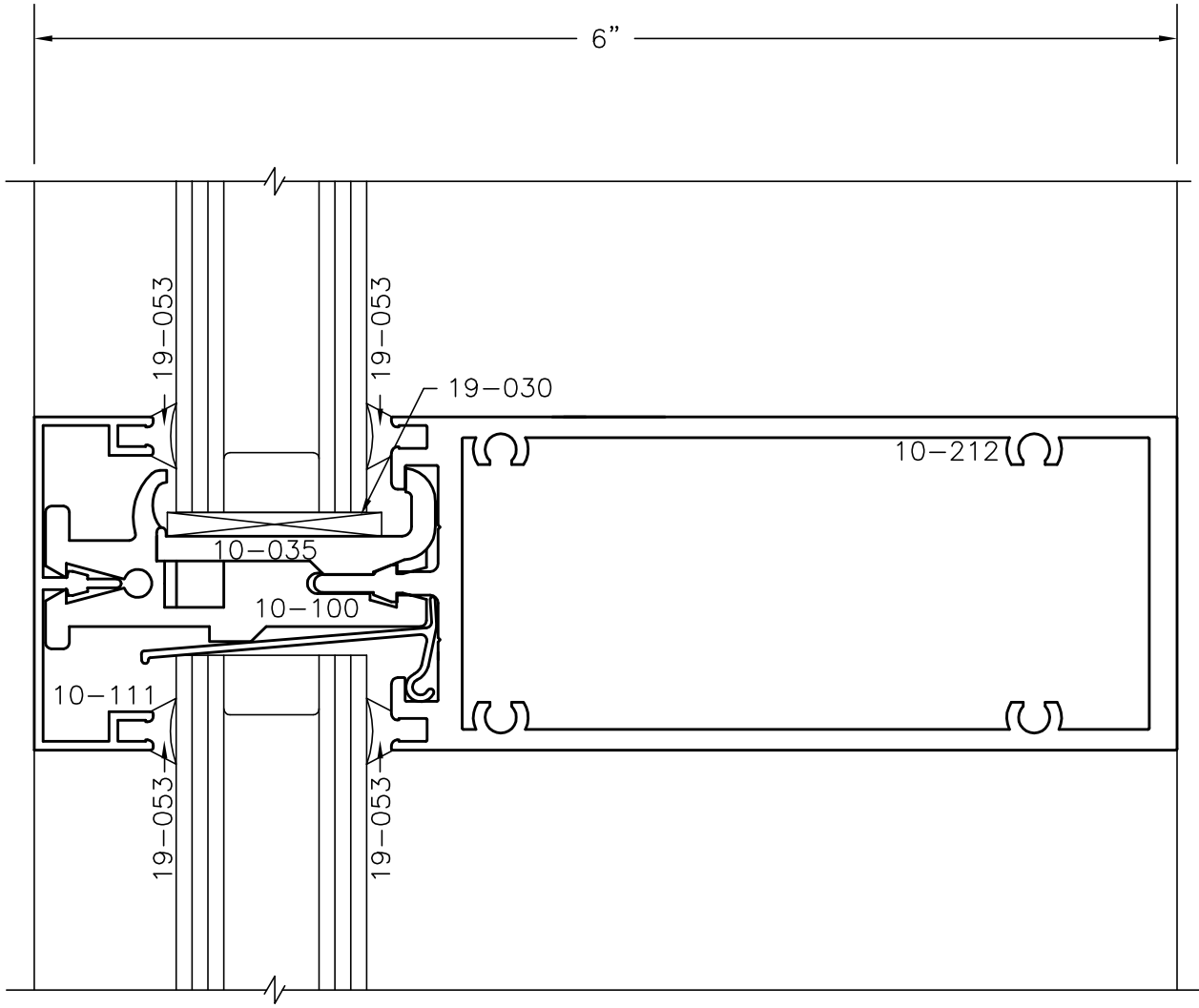
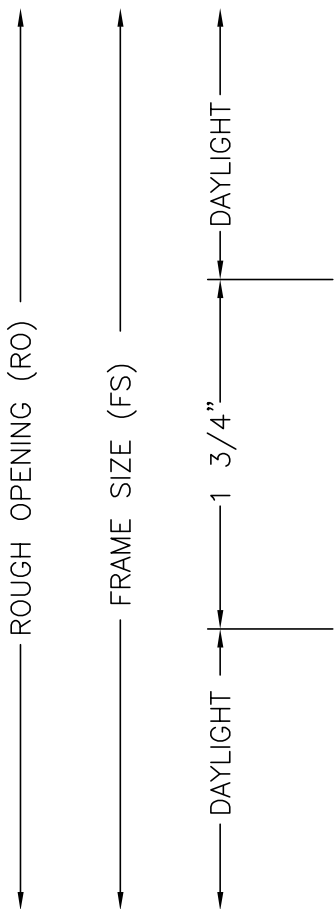

VERTICAL MULLION

SCALE: (1=1) "

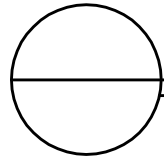

 HORIZONTAL MULLION

SCALE: (1=1) "

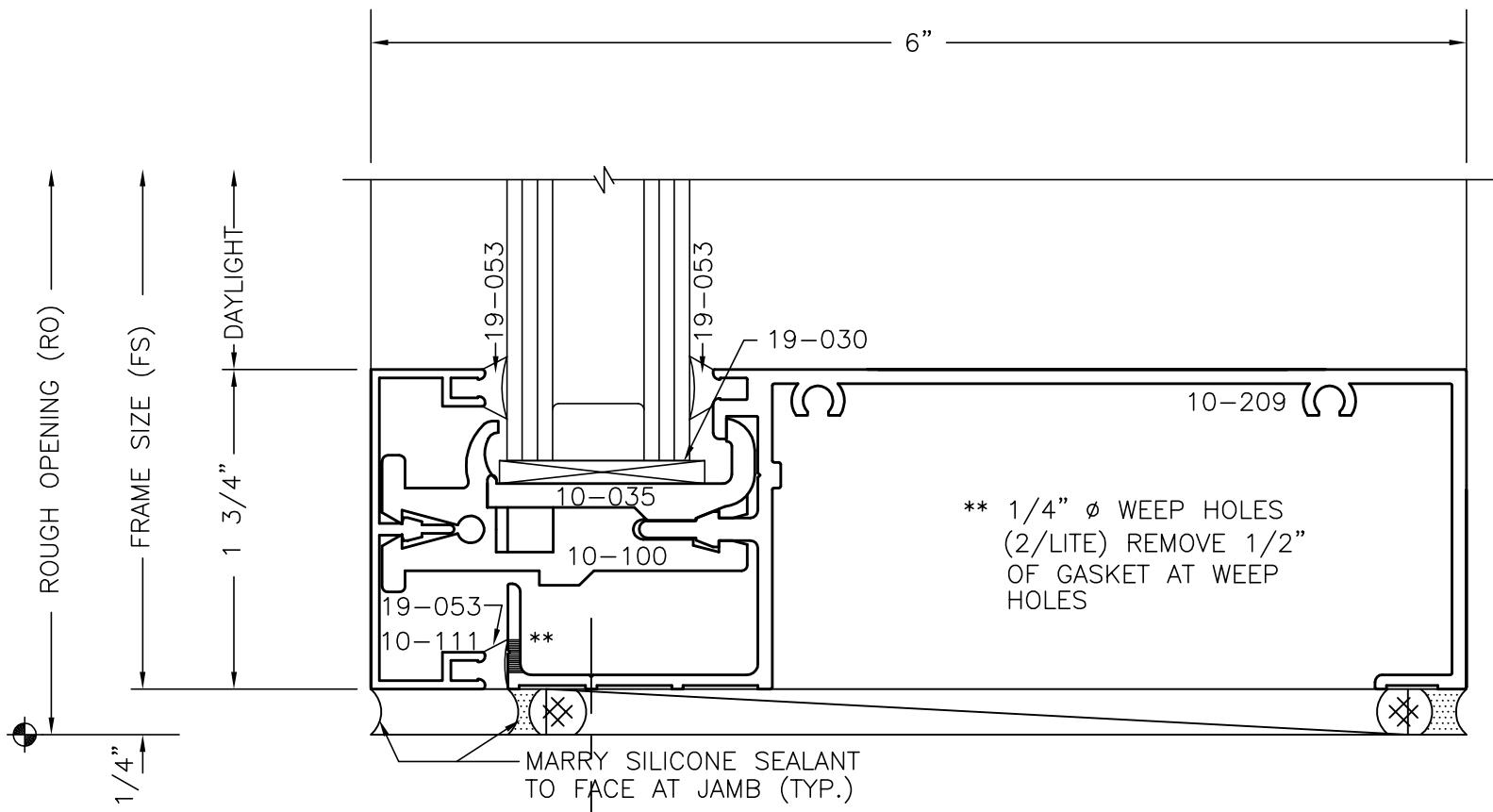

SILL

SCALE: (1=1) "



# REQUEST FOR INFORMATION

**SUB/SUPPLIER:** Great Lakes Systems Inc.

**RFI NO.** 001

**BY:** Jeff French

**DATE:** 6/13/23

**PHONE:** (616) 885-0124

**BID CATEGORY NO.** 8

**BID CATEGORY NAME:** Roofing

**PROJECT:** Montague Area Public Schools – MHS Performance Gymnasium Addition

**PROJECT #:** 22-136.20

**SUBJECT:** Acoustical Dovetail Cover and EPDM roof system

**REF. SPECIFICATION(S):**

**REF. DRAWING(S):**

**REF. DETAIL(S):** 3A/A321

**TYPE OF QUESTION:**

- Civil  
 Structural  
 Architectural  
 Mechanical  
 Electrical  
 Other

**Question:** What is the spec for "Acoustical Dovetail Cover?" There is no spec other than 1/2" HD, please clarify material. It is unclear what you are looking for in the roof system:

- EPDM – mechanically fastened
- 1/2" coverboard HD (you spec 25psi, 20psi is standard), can this be standard?
- 2 layers of 2.5" ISO
- HD cover board, is this substrate?
- 2" dovetail metal deck
- Is this everywhere or just over the gym?

In Bid Category #8 item i refers to parapet wall detail 3A/A321 roofing contractor has to install the ISO but not blocking and nailers. This is a scheduling nightmare, is this the intention of the scope? Can this be clarified or changed?

**RESPONSE BY:**  WinBerg Construction, Inc.    Architect / Engineer

**Response:** Drawings A321 and A322 are being reissued in an addendum for clarification. The 2-inch acoustic dovetail metal deck is only on the high roof over the gym. There is only one layer of 1/2" HD (20psi) Coverboard and it is on top of the insulation.

WinBerg Construction, Inc.

**Signature:**

**Date:**

Architect / Engineer

**Signature:**

*Lori S. Pawlas* APC

**Date:** 6.19.23

Email all RFI's to WinBerg Construction, Inc. – Attn. Jared Mott at [jared@winbergconstruction.com](mailto:jared@winbergconstruction.com)



# REQUEST FOR INFORMATION

**SUB/SUPPLIER:** Versatile Roofing Systems **RFI NO.** 002  
**BY:** Mike Pawlaczyk **DATE:** 6/13/23  
**PHONE:** [231] 233-0019

**BID CATEGORY NO.** 7 **BID CATEGORY NAME:** General Trades

**PROJECT:** **Montague Area Public Schools – MHS Performance Gymnasium Addition**  
**PROJECT #:** **22-136.20**

**SUBJECT:** Formed Metal Wall Panels  
**REF. SPECIFICATION(S):** 07 4213.13 – Formed Metal Wall Panels  
**REF. DRAWING(S):** A301  
**REF. DETAIL(S):** \_\_\_\_\_

**TYPE OF QUESTION:**

- Civil    Structural    Architectural    Mechanical    Electrical    Other

**Question:**

1. For the color is says "match architect's samples." Do I need to figure for custom paint to match or will they choose from the manufacturers paint line?
2. Spec says basis of design is MBCI and the elevation plan A301 calls out Metal Sales FL40 which is an insulated metal panel. Should I stick with the spec for a 12" wide wall panel?
3. On plan A301 it calls out the soffit as MBCI FlexLoc color Royal Blue. They don't have a Royal Blue, will Harbor Blue be acceptable or do I need to figure on custom paint?

**RESPONSE BY:**    WinBerg Construction, Inc.    Architect / Engineer

**Response:**

1. Custom Paint color to match Montague Blue
2. Disregard the Metal Sales FL40 on the drawing. Use the 12-inch wide wall panel in the spec. Drawing A301 will be reissued in an addendum.
3. Custom Paint color to match Montague Blue

WinBerg Construction, Inc.   **Signature:** \_\_\_\_\_   **Date:** \_\_\_\_\_  
 Architect / Engineer   **Signature:** Lori L. Pawlas APC   **Date:** 6.19.23

Email all RFI's to WinBerg Construction, Inc. – Attn. Jared Mott at [jared@winbergconstruction.com](mailto:jared@winbergconstruction.com)



# REQUEST FOR INFORMATION

**SUB/SUPPLIER:** Rockford Construction

**RFI NO.** 003

**BY:** Joshua Thomas

**DATE:** 6/13/2023

**PHONE:** 616-540-9262

**BID CATEGORY NO.** 7

**BID CATEGORY NAME:** General Trades

**PROJECT:** Montague Area Public Schools – MHS Performance Gymnasium Addition

**PROJECT #:** 22-136.20

**SUBJECT:** Bid Bond

**REF. SPECIFICATION(S):** Instructions to Bidders page 4 of 10

**REF. DRAWING(S):**

**REF. DETAIL(S):**

**TYPE OF QUESTION:**

Civil  Structural  Architectural  Mechanical  Electrical  Other

**Question:**

Is this correct or should the bid bond be made out to Montague Area Public Schools?

H. Bid security in the amount of five percent (5%) of the bid, in the form of a Bid Bond, Certified or Cashier's Check is required and to be made payable to Whitehall District Schools. Proposals not accompanied with the proper bid security will not be accepted.

**Subcontractor / Supplier Recommendation:**

Please Clarify

**RESPONSE BY:**



WinBerg Construction, Inc.



Architect / Engineer

**Response:**

Bid bond to be made payable to Montague Area Public Schools.

WinBerg Construction, Inc.

**Signature:**

**Date:**

6/14/23

Architect / Engineer

**Signature:**

**Date:**

Email all RFI's to WinBerg Construction, Inc. – Attn. Jared Mott at [jared@winbergconstruction.com](mailto:jared@winbergconstruction.com)



# REQUEST FOR INFORMATION

**SUB/SUPPLIER:** Rockford Construction

**RFI NO.** 004

**BY:** Joshua Thomas

**DATE:** 6/13/2023

**PHONE:** 616-540-9262

**BID CATEGORY NO.** 7

**BID CATEGORY NAME:** General Trades

**PROJECT:** Montague Area Public Schools – MHS Performance Gymnasium Addition

**PROJECT #:** 22-136.20

**SUBJECT:** Pole Vault Box

**REF. SPECIFICATION(S):**

**REF. DRAWING(S):** A425

**REF. DETAIL(S):** 2/A425

**TYPE OF QUESTION:**

Civil  Structural  Architectural  Mechanical  Electrical  Other

**Question:**

There is a detail of a Pole Vault Box on drawing A425, we cannot find where this is to be installed on the plans.

**Subcontractor / Supplier Recommendation:**

Please clarify the proposed location.

**RESPONSE BY:**



WinBerg Construction, Inc.



Architect / Engineer

**Response:**

Please refer to Sheet I100A for approximate location of pole vault pit in the NE corner of the gym. Exact location to be field verified with CM prior to placement.

WinBerg Construction, Inc.

**Signature:**

**Date:**

6/14/23

Architect / Engineer

**Signature:**

**Date:**

Email all RFI's to WinBerg Construction, Inc. – Attn. Jared Mott at [jared@winbergconstruction.com](mailto:jared@winbergconstruction.com)





# REQUEST FOR INFORMATION

**SUB/SUPPLIER:** Rockford Construction

**RFI NO.** 005

**BY:** Joshua Thomas

**DATE:** 6/13/2023

**PHONE:** 616-540-9262

**BID CATEGORY NO.** 7

**BID CATEGORY NAME:** General Trades

**PROJECT:** Montague Area Public Schools – MHS Performance Gymnasium Addition

**PROJECT #:** 22-136.20

**SUBJECT:** Countertop Support Brackets

**REF. SPECIFICATION(S):**

**REF. DRAWING(S):** A401

**REF. DETAIL(S):** 8,9/A401

**TYPE OF QUESTION:**

Civil  Structural  Architectural  Mechanical  Electrical  Other

**Question:**

Which bid category is responsible for furnishing the countertop support brackets that are grouted in the CMU walls?

**Subcontractor / Supplier Recommendation:**

Please clarify.

**RESPONSE BY:**



WinBerg Construction, Inc.



Architect / Engineer

**Response:**

B.C. No. 7 - General Trades to furnish the countertop support brackets and work with B.C. No. 5 - Masonry to ensure proper locations and heights of support brackets. Please also reference Sheet I301 for interior elevations showing locations of brackets. (2) in each Locker Room and (5) in Concessions.

WinBerg Construction, Inc.

**Signature:**

**Date:** 6/14/23

Architect / Engineer

**Signature:**

**Date:**

Email all RFI's to WinBerg Construction, Inc. – Attn. Jared Mott at [jared@winbergconstruction.com](mailto:jared@winbergconstruction.com)



# REQUEST FOR INFORMATION

**SUB/SUPPLIER:** Rockford Construction

**RFI NO.** 006

**BY:** Joshua Thomas

**DATE:** 6/13/2023

**PHONE:** 616-540-9262

**BID CATEGORY NO.** 7

**BID CATEGORY NAME:** General Trades

**PROJECT:** Montague Area Public Schools – MHS Performance Gymnasium Addition

**PROJECT #:** 22-136.20

**SUBJECT:** Appliances

**REF. SPECIFICATION(S):**

**REF. DRAWING(S):** A401

**REF. DETAIL(S):** Accessory Matrix

**TYPE OF QUESTION:**

Civil  Structural  Architectural  Mechanical  Electrical  Other

**Question:**

Which bid category is responsible for installing the Owner Purchased appliances?

**Subcontractor / Supplier Recommendation:**

Please clarify.

**RESPONSE BY:**



WinBerg Construction, Inc.



Architect / Engineer

**Response:**

All new appliances will be Owner furnished and Owner and/or Construction Manager installed - please disregard any reference to Contractor installed for appliances.

WinBerg Construction, Inc.

**Signature:**

**Date:**

6/14/23

Architect / Engineer

**Signature:**

**Date:**

Email all RFI's to WinBerg Construction, Inc. – Attn. Jared Mott at [jared@winbergconstruction.com](mailto:jared@winbergconstruction.com)



# REQUEST FOR INFORMATION

**SUB/SUPPLIER:** Rockford Construction

**RFI NO.** 007

**BY:** Joshua Thomas

**DATE:** 6/13/2023

**PHONE:** 616-540-9262

**BID CATEGORY NO.** 7

**BID CATEGORY NAME:** General Trades

**PROJECT:** Montague Area Public Schools – MHS Performance Gymnasium Addition

**PROJECT #:** 22-136.20

**SUBJECT:** Toilet / Bath Accessories

**REF. SPECIFICATION(S):**

**REF. DRAWING(S):** A401

**REF. DETAIL(S):** Accessory Matrix

**TYPE OF QUESTION:**

Civil  Structural  Architectural  Mechanical  Electrical  Other

**Question:**

Who is responsible for furnishing and installing the fold down shower seat?

**Subcontractor / Supplier Recommendation:**

Please clarify.

**RESPONSE BY:**



WinBerg Construction, Inc.



Architect / Engineer

**Response:**

The fold-down shower seat is furnished as part of the shower unit. Furnish and installation to be by B.C. No. 19 - Plumbing.

WinBerg Construction, Inc.

**Signature:**

**Date:**

6/14/23

Architect / Engineer

**Signature:**

**Date:**

Email all RFI's to WinBerg Construction, Inc. – Attn. Jared Mott at [jared@winbergconstruction.com](mailto:jared@winbergconstruction.com)



# REQUEST FOR INFORMATION

**SUB/SUPPLIER:** Rockford Construction

**RFI NO.** 008

**BY:** Joshua Thomas

**DATE:** 6/13/2023

**PHONE:** 616-540-9262

**BID CATEGORY NO.** 7

**BID CATEGORY NAME:** General Trades

**PROJECT:** Montague Area Public Schools – MHS Performance Gymnasium Addition

**PROJECT #:** 22-136.20

**SUBJECT:** Scoreboards

**REF. SPECIFICATION(S):**

**REF. DRAWING(S):** A401

**REF. DETAIL(S):** Accessory Matrix

**TYPE OF QUESTION:**

Civil  Structural  Architectural  Mechanical  Electrical  Other

**Question:**

The accessory matrix is calling for the scoreboards to be Contractor Purchased & Contractor Installed. The scope of work for bid category #7 says that the scoreboards will be furnished and installed by the owner.

**Subcontractor / Supplier Recommendation:**

Please clarify.

**RESPONSE BY:**



WinBerg Construction, Inc.



Architect / Engineer

**Response:**

The scoreboards will be furnished and installed by the Owner as part of a future bid package. Please disregard any reference to Contractor Installed for the scoreboards.

WinBerg Construction, Inc.

**Signature:**

**Date:**

6/14/23

Architect / Engineer

**Signature:**

**Date:**

Email all RFI's to WinBerg Construction, Inc. – Attn. Jared Mott at [jared@winbergconstruction.com](mailto:jared@winbergconstruction.com)



# REQUEST FOR INFORMATION

**SUB/SUPPLIER:** Kuhn Specialty Flooring **RFI NO.** 009  
**BY:** Jeff Williams **DATE:** 6/14/23  
**PHONE:** [269] 832-4101

**BID CATEGORY NO.** 14 **BID CATEGORY NAME:** Resilient Athletic Flooring

**PROJECT:** **Montague Area Public Schools – MHS Performance Gymnasium Addition**  
**PROJECT #:** **22-136.20**

**SUBJECT:** Resilient Athletic and Rubber Sheet Flooring  
**REF. SPECIFICATION(S):** 09 6766 – Fluid-Applied Athletic Flooring, 09 6566 – Resilient Athletic Flooring  
**REF. DRAWING(S):** I001, I100A, and I101A  
**REF. DETAIL(S):** \_\_\_\_\_

**TYPE OF QUESTION:**

- Civil    Structural    Architectural    Mechanical    Electrical    Other

**Question:**

1. The schedule calls for RAF-1 Tarkett Polyturf Plus 7+2 system and is spec section 09 6766 – Fluid-Applied Athletic Flooring. This is not listed in Bid Category No. 14 – Resilient Athletic Flooring, shouldn't it be?
2. What product is the spec section 09 6566 – Resilient Athletic Flooring referring to and where?

**RESPONSE BY:**    WinBerg Construction, Inc.    Architect / Engineer

**Response:**

1. Please ADD specification section 09 6766 – Fluid-Applied Athletic Flooring to Bid Category No. 14 – Resilient Athletic Flooring. This is per the material selection schedule on I001 noted as RAF-1.
2. 09 6566 – Resilient Athletic Flooring is for RBS-1 and RBS-2 as noted on the material selection schedule on sheet I001. This is to be furnished and installed by Bid Category No. 14 – Resilient Athletic Flooring.
3. REMOVE item "i. Cut-in MCAT logos at Fitness 009 rubber sheet flooring (10) required will be coordinated with Owner fitness equipment layout" from Bid Category No. 12 – Flooring scope of work and ADD to Bid Category No. 14 – Resilient Athletic Flooring scope of work.

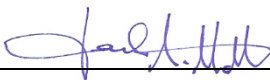
WinBerg Construction, Inc.   **Signature:**    **Date:** 6/14/23  
Architect / Engineer   **Signature:** \_\_\_\_\_   **Date:** \_\_\_\_\_

Email all RFI's to WinBerg Construction, Inc. – Attn. Jared Mott at [jared@winbergconstruction.com](mailto:jared@winbergconstruction.com)



# REQUEST FOR INFORMATION

**SUB/SUPPLIER:** Wood Trucking

**RFI NO.** 010

**BY:** Ben Hylland

**DATE:** 6/14/23

**PHONE:** [231] 722-2042

**BID CATEGORY NO.** 1

**BID CATEGORY NAME:** Site Work

**PROJECT:** Montague Area Public Schools – MHS Performance Gymnasium Addition

**PROJECT #:** 22-136.20

**SUBJECT:** Geotech Report, Sheet Piling, and Paving Scope

**REF. SPECIFICATION(S):**

**REF. DRAWING(S):**

**REF. DETAIL(S):**

**TYPE OF QUESTION:**

- Civil
  Structural
  Architectural
  Mechanical
  Electrical
  Other

**Question:**

- Where is the geotechnical report?
- Is the new gym far enough away from the existing building to dig the foundation without sheet piling?
- Bid scope item F. says to include all new paving?
- Bid scope item L. has us doing asphalt patching?

**RESPONSE BY:**

- WinBerg Construction, Inc.
  Architect / Engineer

**Response:**

- The soil boring logs and geotechnical report will be issued as part of Addendum No. 1.
- Yes, the new gym is far enough away from the existing building – no sheet piling required.
- Bid scope item F. shall read, "Base Bid to include removal of all existing asphalt paving." All new asphalt paving is to be by Bid Category No. 2 – Asphalt Paving.
- Bid scope item L. shall read, "Sawcut and remove asphalt paving, install gravel/aggregate base." Fine grading and asphalt patching to be by Bid Category No. 2 – Asphalt Paving.

WinBerg Construction, Inc.

**Signature:**

**Date:** 6/14/23

Architect / Engineer

**Signature:**

**Date:**

Email all RFI's to WinBerg Construction, Inc. – Attn. Jared Mott at [jared@winbergconstruction.com](mailto:jared@winbergconstruction.com)



# REQUEST FOR INFORMATION

**SUB/SUPPLIER:** Premier Caulking Inc.

**RFI NO.** 011

**BY:** Ike Wells

**DATE:** 6/15/23

**PHONE:** [616] 454-5227

**BID CATEGORY NO.** 9

**BID CATEGORY NAME:** Caulking and Sealants

**PROJECT:** Montague Area Public Schools – MHS Performance Gymnasium Addition

**PROJECT #:** 22-136.20

**SUBJECT:** Firestopping

**REF. SPECIFICATION(S):** 07 8443 – Joint Firestopping

**REF. DRAWING(S):**

**REF. DETAIL(S):**

**TYPE OF QUESTION:**

Civil  Structural  Architectural  Mechanical  Electrical  Other

**Question:**

1. Who is responsible for firestopping the tops of the rated masonry walls?

**RESPONSE BY:**  WinBerg Construction, Inc.  Architect / Engineer

**Response:**

1. Bid Category No. 9 – Caulking and Sealants shall firestop the top of the rated masonry walls.

WinBerg Construction, Inc.

**Signature:**

**Date:** 6/15/23

Architect / Engineer

**Signature:**

**Date:**

Email all RFI's to WinBerg Construction, Inc. – Attn. Jared Mott at [jared@winbergconstruction.com](mailto:jared@winbergconstruction.com)



# REQUEST FOR INFORMATION

**SUB/SUPPLIER:** Architectural Openings & Access **RFI NO.** 012  
**BY:** Brit Herron **DATE:** 6/15/23  
**PHONE:** (616) 363-6854

**BID CATEGORY NO.** 7 **BID CATEGORY NAME:** General Trades

**PROJECT:** Montague Area Public Schools – MHS Performance Gymnasium Addition  
**PROJECT #:** 22-136.20

**SUBJECT:** Fire Rated Doors for Openings 108A, 112, and 114  
**REF. SPECIFICATION(S):**  
**REF. DRAWING(S):** A501  
**REF. DETAIL(S):**

**TYPE OF QUESTION:**

Civil  Structural  Architectural  Mechanical  Electrical  Other

**Question:**

- On page A-501, openings 108A, 112, and 114 are called out to carry a 120min, or 2-hour fire rating for the wood doors and hollow metal frames. Wood doors only carry a fire rating up to 90min. or 1 ½" hour. To meet the 2-hour fire rating, we will need to provide hollow metal doors for these openings. Please advise how you would like us to proceed quoting these openings.

**RESPONSE BY:**  WinBerg Construction, Inc.  Architect / Engineer

**Response:** Use 90-minute FR wood door for 108A, 112 and 114.  
Drawing A501 being reissued in an addendum.

WinBerg Construction, Inc. **Signature:** \_\_\_\_\_ **Date:** \_\_\_\_\_  
Architect / Engineer **Signature:** Lori L. Pavlias APC **Date:** 6.19.23

Email all RFI's to WinBerg Construction, Inc. – Attn. Jared Mott at [jared@winbergconstruction.com](mailto:jared@winbergconstruction.com)





# REQUEST FOR INFORMATION

**SUB/SUPPLIER:** LG2 **RFI NO.** 013  
**BY:** Rick Murphy **DATE:** 6/15/23  
**PHONE:** [616] 745-5177

**BID CATEGORY NO.** 7 **BID CATEGORY NAME:** General Trades

**PROJECT:** Montague Area Public Schools – MHS Performance Gymnasium Addition  
**PROJECT #:** 22-136.20

**SUBJECT:** Locker Benches  
**REF. SPECIFICATION(S):** 10 5113 – Metal Lockers  
**REF. DRAWING(S):** I301  
**REF. DETAIL(S):**

**TYPE OF QUESTION:**

- Civil  Structural  Architectural  Mechanical  Electrical  Other

**Question:**

- The specification calls for Locker Benches, but the drawings , Sheet I301 – Interior Elevations, do not show any. Are they indeed required? If so, what length each and how many?

**RESPONSE BY:**  WinBerg Construction, Inc.  Architect / Engineer

**Response:**

- Locker Benches will be provided and installed by the Owner as part of their FFE package. Please remove any reference to locker benches from Bid Category No. 7 – General Trades scope of work.

WinBerg Construction, Inc. **Signature:**  **Date:** 6/16/23  
 Architect / Engineer **Signature:** \_\_\_\_\_ **Date:** \_\_\_\_\_

Email all RFI's to WinBerg Construction, Inc. – Attn. Jared Mott at [jared@winbergconstruction.com](mailto:jared@winbergconstruction.com)



# REQUEST FOR INFORMATION

**SUB/SUPPLIER:** White Lake Glass

**RFI NO.** 014

**BY:** Justin Visconti

**DATE:** 6/15/23

**PHONE:** [231] 578-7541

**BID CATEGORY NO.** 10

**BID CATEGORY NAME:** Aluminum Storefront / Doors / Glass and Glazing

**PROJECT:** Montague Area Public Schools – MHS Performance Gymnasium Addition

**PROJECT #:** 22-136.20

**SUBJECT:** Glass

**REF. SPECIFICATION(S):** 08 8000 - Glazing

**REF. DRAWING(S):** A501

**REF. DETAIL(S):** Interior and Exterior Frame Elevations

**TYPE OF QUESTION:**

Civil    Structural    Architectural    Mechanical    Electrical    Other

**Question:**

1. Can the glass make-up please be clarified between Sheet A501 and the specifications?

**RESPONSE BY:**    WinBerg Construction, Inc.    Architect / Engineer

**Response:**

**IG-2 to be used on West Exposure in Gymnasium Room #001.**

WinBerg Construction, Inc.

**Signature:** \_\_\_\_\_

**Date:** \_\_\_\_\_

Architect / Engineer

**Signature:** *Lori S. Pawlitas* APC

**Date:** 6.19.23

Email all RFI's to WinBerg Construction, Inc. – Attn. Jared Mott at [jared@winbergconstruction.com](mailto:jared@winbergconstruction.com)



# REQUEST FOR INFORMATION

**SUB/SUPPLIER:** Brigade Fire Protection **RFI NO.** 015  
**BY:** Dean Chance **DATE:** 6/16/23  
**PHONE:** 616-784-1644

**BID CATEGORY NO.** 18 **BID CATEGORY NAME:** Fire Suppression

**PROJECT:** Montague Area Public Schools – MHS Performance Gymnasium Addition  
**PROJECT #:** 22-136.20

**SUBJECT:** Fire Sprinkler As-Builts  
**REF. SPECIFICATION(S):**  
**REF. DRAWING(S):**  
**REF. DETAIL(S):**

**TYPE OF QUESTION:**

- Civil  Structural  Architectural  Mechanical  Electrical  Other

**Question:**

Are as-built sprinkler drawings available for the space adjacent to the addition?

**Subcontractor / Supplier Recommendation:**

**RESPONSE BY:**  WinBerg Construction, Inc.  Architect / Engineer

**Response:**

No, the Owner does not have any As-Built plans for this area as it does not currently have fire suppression in it. The two Janitor's Closets are the only rooms in that area that have upright sprinklers tied off of the domestic with a butterfly valve and flow switch tied into the fire alarm system.

WinBerg Construction, Inc. **Signature:**  **Date:** 6/16/23  
 Architect / Engineer **Signature:** \_\_\_\_\_ **Date:** \_\_\_\_\_

Email all RFI's to WinBerg Construction, Inc. – Attn. Jared Mott at [jared@winbergconstruction.com](mailto:jared@winbergconstruction.com)



# REQUEST FOR INFORMATION

**SUB/SUPPLIER:** JK Masonry, Inc.

**RFI NO.** 016

**BY:** Joe Wiseman

**DATE:** 6/16/23

**PHONE:** [616] 784-3081 Ext. 103

**BID CATEGORY NO.** 5

**BID CATEGORY NAME:** Masonry

**PROJECT:** Montague Area Public Schools – MHS Performance Gymnasium Addition

**PROJECT #:** 22-136.20

**SUBJECT:** Winter Conditions Allowance

**REF. SPECIFICATION(S):**

**REF. DRAWING(S):**

**REF. DETAIL(S):**

**TYPE OF QUESTION:**

Civil  Structural  Architectural  Mechanical  Electrical  Other

**Question:**

- Are the masons responsible for Winter Conditions? If so, I would like to request a CM supplied allowance.

**RESPONSE BY:**  WinBerg Construction, Inc.  Architect / Engineer

**Response:**

- Yes, Winter Conditions are the responsibility of the masons. Bid Category No. 5 – Masonry is to include an Allowance of \$50,000 for Winter Conditions.

WinBerg Construction, Inc.

**Signature:**

**Date:** 6/16/23

Architect / Engineer

**Signature:**

**Date:**

Email all RFI's to WinBerg Construction, Inc. – Attn. Jared Mott at [jared@winbergconstruction.com](mailto:jared@winbergconstruction.com)



# REQUEST FOR INFORMATION

**SUB/SUPPLIER:** Cofessco Fire Protection

**RFI NO.** 017

**BY:** Joe Stine

**DATE:** 6/16/23

**PHONE:** [231] 726-2396

**BID CATEGORY NO.** 18

**BID CATEGORY NAME:** Fire Suppression

**PROJECT:** Montague Area Public Schools – MHS Performance Gymnasium Addition

**PROJECT #:** 22-136.20

**SUBJECT:** Preaction System, Existing Tie-Ins, and Riser Locations

**REF. SPECIFICATION(S):**

**REF. DRAWING(S):** FP100A and FP101A

**REF. DETAIL(S):**

**TYPE OF QUESTION:**

- Civil
- Structural
- Architectural
- Mechanical
- Electrical
- Other

**Question:**

1. During the Pre-Bid Meeting it was stated that everything is going to be wet system, on Sheets FP100A and FP101A it calls for a preaction system in the Gymnasium. How are we to bid, per the plans?
2. Keyed Note 8 on Sheet FP101A in Corridor 112 states to connect to existing system. Is this just for the Corridor 112 or what spaces is this to include?
3. Where are the riser(s) to be located and water main coming into the building?
4. On Sheet FP101A it shows FP Risers #1 and #2 going up through the chases, is this correct?

**RESPONSE BY:**

WinBerg Construction, Inc.

Architect / Engineer

**Response:**

1. The Owner does **not** want a preaction system in the Gymnasium – bid all new areas as a wet system. Sprinkler head guards in Gymnasium shall be Viking Model D-1.
2. This should be pointing to the areas on the East side of the firewall that are in the existing building. There will be some reworking of heads based on the room changes. Also, Passage 123 on the South side of the firewall shall be tied into the existing system. The intent is to have everything on the addition side fed from the new system, everything on the existing side fed from the existing system, so we are not passing through the 2-hr rated wall.
3. 8" water main is coming in on the lower level in the NE corner of the building. Riser to be on the North wall in this corner. Main coming off from riser shall not penetrate through the track floor – see response 4 below.
4. FP riser #1 [#2 is eliminated because of no preaction system] shall run South below track and above Passage 003, Storage 004A, and Trainer 004, turn West under the track, and into the East mechanical chase to feed up for upper Gymnasium main.

WinBerg Construction, Inc.

**Signature:**

**Date:**

6/16/23

Architect / Engineer

**Signature:**

**Date:**

Email all RFI's to WinBerg Construction, Inc. – Attn. Jared Mott at [jared@winbergconstruction.com](mailto:jared@winbergconstruction.com)



# REQUEST FOR INFORMATION

**SUB/SUPPLIER:** Van Dellen Steel **RFI NO.** 018  
**BY:** Jim DeVries **DATE:** 6/16/23  
**PHONE:** [616] 698-9950

**BID CATEGORY NO.** 6 **BID CATEGORY NAME:** Steel

**PROJECT:** **Montague Area Public Schools – MHS Performance Gymnasium Addition**  
**PROJECT #:** **22-136.20**

**SUBJECT:** Angles

**REF. SPECIFICATION(S):** \_\_\_\_\_

**REF. DRAWING(S):** A321 and A322

**REF. DETAIL(S):** 3A/A321 and 5A/A322

**TYPE OF QUESTION:**

- Civil  Structural  Architectural  Mechanical  Electrical  Other

**Question:**

- On Details 3A/A321 and 5A/A322 there is a top of wall angle support, but no size shown. There are also similar conditions that do not show angle. Please confirm the angle(s) are required, and if so, what size and locations please?

**RESPONSE BY:**  WinBerg Construction, Inc.  Architect / Engineer

**Response:** The L4X4 angles shown in details 3A/A321 and 5A/A322 are not required due to the callout for the Prebuck Parapet Cap. This Cap, when engineered by the supplier, can cantilever out past the face of CMU and does not require additional structural steel support. Coordinate with the supplier of the Prebuck Cap.

Note: the information above is from the structural engineer

Please remove furnish of angles from Bid Category No. 6 - Steel scope of work item f. and install of angles from Bid Category No. 5 - Masonry scope of work item h.

WinBerg Construction, Inc. **Signature:**  **Date:** 6/19/23  
 Architect / Engineer **Signature:** \_\_\_\_\_ **Date:** \_\_\_\_\_

Email all RFI's to WinBerg Construction, Inc. – Attn. Jared Mott at [jared@winbergconstruction.com](mailto:jared@winbergconstruction.com)



# REQUEST FOR INFORMATION

**SUB/SUPPLIER:** Lakeshore Glass & Metals, Inc. **RFI NO.** 019  
**BY:** Mark Hamberg **DATE:** 6/16/23  
**PHONE:** (616) 395-8555

**BID CATEGORY NO.** 10 **BID CATEGORY NAME:** Aluminum Storefront / Doors / Glass and Glazing

**PROJECT:** Montague Area Public Schools – MHS Performance Gymnasium Addition  
**PROJECT #:** 22-136.20

**SUBJECT:** Glass  
**REF. SPECIFICATION(S):** 08 8000 – Glazing  
**REF. DRAWING(S):** A501  
**REF. DETAIL(S):** Interior and Exterior Frame Elevations

**TYPE OF QUESTION:**

Civil  Structural  Architectural  Mechanical  Electrical  Other

**Question:**

- The glass in W1 openings on print are labeled IG-1, spec calls out IG-2 for gymnasium which is acid etched on third surface. Which one is correct?
- Interior frame 10, glass is labeled as IG-1, can this be 1/4" glass? If it is 1" glass it would not be Low-E glass?

**RESPONSE BY:**  WinBerg Construction, Inc.  Architect / Engineer

**Response:**

- IG-2 is West exposure Gymnasium Room #001.
- Interior frame 10 can be 1/4" glass GL-1.

WinBerg Construction, Inc. **Signature:** \_\_\_\_\_ **Date:** \_\_\_\_\_  
 Architect / Engineer **Signature:** *Lori L. Pawlitas* APC **Date:** 6.19.23

Email all RFI's to WinBerg Construction, Inc. – Attn. Jared Mott at [jared@winbergconstruction.com](mailto:jared@winbergconstruction.com)



# REQUEST FOR INFORMATION

**SUB/SUPPLIER:** Rieth-Riley Construction Co., Inc.

**RFI NO.** 020

**BY:** Matt Skiver

**DATE:** 6/19/23

**PHONE:** [231] 845-7031 Ext. 29024

**BID CATEGORY NO.** 2

**BID CATEGORY NAME:** Asphalt Paving

**PROJECT:** Montague Area Public Schools – MHS Performance Gymnasium Addition

**PROJECT #:** 22-136.20

**SUBJECT:** Asphalt Paving Mix Designs and Thickness

**REF. SPECIFICATION(S):** 32 1213 – Asphalt Paving

**REF. DRAWING(S):** C101 and C104

**REF. DETAIL(S):** Light Duty and Heavy Duty Pavement Sections on Sheet C104

**TYPE OF QUESTION:**

Civil    Structural    Architectural    Mechanical    Electrical    Other

**Question:**

1. Specifications call for 64-22 liquid asphalt binder. Recommend switching to 64-28 liquid as it is not as hard and will not develop cracking as early as the 64-22 liquid.
2. Recommend switching all leveling course and base courses to 4e1.
3. All of the varying thicknesses of heavy duty and standard duty in the aisles and parking spots creates a lot of extra work. Recommend switching everything to the same base thickness, same leveling course and same top course throughout. Recommend 4" [2+2] of asphalt paving throughout.

**RESPONSE BY:**



WinBerg Construction, Inc.



Architect / Engineer

**Response:**

1. Please use the 64-28 liquid asphalt binder as recommended.
2. All leveling and base course asphalt paving to be MDOT 4e1.
3. All new asphalt areas are to receive 8" of limestone 21AA base. All existing asphalt areas being removed shall be topped with limestone 21AA base to achieve desired grades. All new asphalt paving shall be 4" total thickness, 2" MDOT 4e1 leveling course and 2" MDOT 4e1 top course.

WinBerg Construction, Inc.

**Signature:**

**Date:**

6/19/23

Architect / Engineer

**Signature:**

**Date:**

Email all RFI's to WinBerg Construction, Inc. – Attn. Jared Mott at [jared@winbergconstruction.com](mailto:jared@winbergconstruction.com)





# REQUEST FOR INFORMATION

**SUB/SUPPLIER:** Muskegon Quality Builders, Inc. **RFI NO.** 021  
**BY:** Aaron Cribley **DATE:** 6/19/23  
**PHONE:** [231] 733-4278

**BID CATEGORY NO.** 7 **BID CATEGORY NAME:** General Trades

**PROJECT:** Montague Area Public Schools – MHS Performance Gymnasium Addition  
**PROJECT #:** 22-136.20

**SUBJECT:** Exterior Sheathing Behind Metal Panels  
**REF. SPECIFICATION(S):** 06 1600 – Sheathing  
**REF. DRAWING(S):** A323  
**REF. DETAIL(S):** 1, 1B, 1C, and 7 on Sheet A323

**TYPE OF QUESTION:**

- Civil  Structural  Architectural  Mechanical  Electrical  Other

**Question:**

- At the entry behind the metal panels, is this Glass-Mat sheathing? If so, who is responsible for furnishing and installing?

**RESPONSE BY:**  WinBerg Construction, Inc.  Architect / Engineer

**Response:**

- Yes, the sheathing behind the metal panels at the entry is to be Glass-Mat per Specification Section 06 1600 – Sheathing. This shall be furnished and installed by Bid Category No. 11 – LPDA. All non-Glass-Mat sheathing [wood] is to be by Bid Category No. 7 – General Trades.

WinBerg Construction, Inc. **Signature:**  **Date:** 6/19/23  
 Architect / Engineer **Signature:** \_\_\_\_\_ **Date:** \_\_\_\_\_

Email all RFI's to WinBerg Construction, Inc. – Attn. Jared Mott at [jared@winbergconstruction.com](mailto:jared@winbergconstruction.com)



# REQUEST FOR INFORMATION

**SUB/SUPPLIER:** North End Painting **RFI NO.** 022  
**BY:** John Tangney **DATE:** 6/19/23  
**PHONE:** [231] 750-7804

**BID CATEGORY NO.** 15 **BID CATEGORY NAME:** Painting

**PROJECT:** Montague Area Public Schools – MHS Performance Gymnasium Addition  
**PROJECT #:** 22-136.20

**SUBJECT:** Logo and Accent Painting

**REF. SPECIFICATION(S):**

**REF. DRAWING(S):** I301

**REF. DETAIL(S):** 12, 14, and 16 on Sheet I301

**TYPE OF QUESTION:**

- Civil  Structural  Architectural  Mechanical  Electrical  Other

**Question:**

1. Are the painters responsible for the "Montague Wildcats" per Detail 12/I301?
2. Are the painters responsible for the MCAT logo on the Fitness Room wall per Detail 14/I301?
3. Are the painters responsible for the "Let's Go Wildcats!" per Detail 16/I301?

**RESPONSE BY:**  WinBerg Construction, Inc.  Architect / Engineer

**Response:**

1. Bid Category No. 15 – Painting shall only be responsible for the MCAT logo in the Fitness Room per Detail 14 on Sheet I301. The other two areas per Details 12 and 16 on Sheet I301 were possible branding areas identified for the school, but the school has not settled on the exact verbiage or look at this time.

WinBerg Construction, Inc. **Signature:**  **Date:** 6/19/23  
 Architect / Engineer **Signature:** \_\_\_\_\_ **Date:** \_\_\_\_\_

Email all RFI's to WinBerg Construction, Inc. – Attn. Jared Mott at [jared@winbergconstruction.com](mailto:jared@winbergconstruction.com)



# REQUEST FOR INFORMATION

**SUB/SUPPLIER:** Real Steel Manufacturing

**RFI NO.** 023

**BY:** Mike Johnson

**DATE:** 6/19/2023

**PHONE:** 231-457-4673

**BID CATEGORY NO.** 06

**BID CATEGORY NAME:** Structural Steel

**PROJECT:** Montague Area Public Schools – MHS Performance Gymnasium Addition

**PROJECT #:** 22-136.20

**SUBJECT:** Steel Bollards

**REF. SPECIFICATION(S):** Project Manual Vol. 1, Pg 9 & 243

**REF. DRAWING(S):**

**REF. DETAIL(S):**

**TYPE OF QUESTION:**

- Civil  
  Structural  
  Architectural  
  Mechanical  
  Electrical  
  Other

**Question:** Pg. 9 of the Volume 1 Project Manual lists that Concrete is to furnish steel bollards. Pg. 243 lists Metal Fab to Furnish. Which one is it?

Also, What Schedule Pipe should be furnished? 40 or 80?

**Subcontractor / Supplier Recommendation:**

**RESPONSE BY:**  WinBerg Construction, Inc.    Architect / Engineer

**Response:**

All pipe bollards are to be schedule 80 and are to be furnished and installed by Bid Category No. 4 - Concrete.

WinBerg Construction, Inc.

**Signature:**

**Date:**

6/19/23

Architect / Engineer

**Signature:**

**Date:**

Email all RFI's to WinBerg Construction, Inc. – Attn. Jared Mott at [jared@winbergconstruction.com](mailto:jared@winbergconstruction.com)



# REQUEST FOR INFORMATION

**SUB/SUPPLIER:** Real Steel Manufacturing **RFI NO.** 024  
**BY:** Mike Johnson **DATE:** 6/19/2023  
**PHONE:** 231-457-4673

**BID CATEGORY NO.** 06 **BID CATEGORY NAME:** Structural Steel

**PROJECT:** Montague Area Public Schools – MHS Performance Gymnasium Addition  
**PROJECT #:** 22-136.20

**SUBJECT:** Steel Decking Attachment

**REF. SPECIFICATION(S):**

**REF. DRAWING(S):**

**REF. DETAIL(S):**

**TYPE OF QUESTION:**

- Civil  Structural  Architectural  Mechanical  Electrical  Other

**Question:** Can all steel decking be mechanically fastened using SJI appropriate screw fasteners or does decking need to be puddle welded?

**Subcontractor / Supplier Recommendation:**

**RESPONSE BY:**  WinBerg Construction, Inc.  Architect / Engineer

**Response:** Steel deck can be mechanically fastened. The contractor shall submit a substitution package that shows the mechanical fastening meets the strength requirements that meet or exceed the welds.

WinBerg Construction, Inc. **Signature:** \_\_\_\_\_ **Date:** \_\_\_\_\_  
 Architect / Engineer **Signature:** B. Sherman **Date:** 6/20/23

Email all RFI's to WinBerg Construction, Inc. – Attn. Jared Mott at [jared@winbergconstruction.com](mailto:jared@winbergconstruction.com)



# REQUEST FOR INFORMATION

**SUB/SUPPLIER:** Real Steel Manufacturing

**RFI NO.** 025

**BY:** Mike Johnson

**DATE:** 6/19/2023

**PHONE:** 231-457-4673

**BID CATEGORY NO.** 06

**BID CATEGORY NAME:** Structural Steel

**PROJECT:** Montague Area Public Schools – MHS Performance Gymnasium Addition

**PROJECT #:** 22-136.20

**SUBJECT:** Rails for Gym Bleachers

**REF. SPECIFICATION(S):**

**REF. DRAWING(S):**

**REF. DETAIL(S):**

**TYPE OF QUESTION:**

- Civil
  Structural
  Architectural
  Mechanical
  Electrical
  Other

**Question:** Are railings for Interior Bleachers to be supplied by Metal Fabricator or other?

**Subcontractor / Supplier Recommendation:**

**RESPONSE BY:**  WinBerg Construction, Inc.  Architect / Engineer

**Response:**

All railings for bleachers are furnished and installed by Bid Category No. 16 - Bleachers.

WinBerg Construction, Inc.

**Signature:**

**Date:**

6/19/23

Architect / Engineer

**Signature:**

**Date:**

Email all RFI's to WinBerg Construction, Inc. – Attn. Jared Mott at [jared@winbergconstruction.com](mailto:jared@winbergconstruction.com)